

627/628 SERIES



627/628 SERIES ORDERING CODE

Example:

627-025-220-047

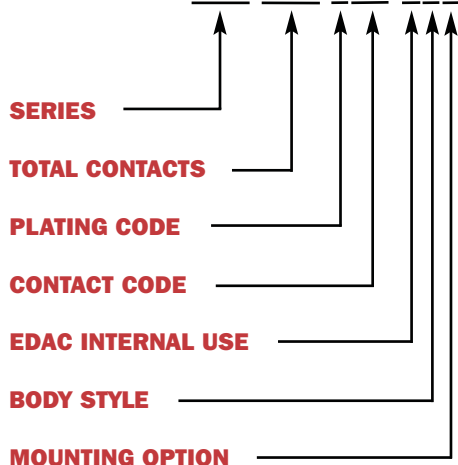

FEATURES

- Both low and high profiles available.
- .109" (2.77mm) contact spacing x .112" (2.82mm) row spacing.
- Plug and receptacle in 9-, 15-, 25-, 37- and 50-pin contact sizes.
- Pin and socket contact mating design with PC tail termination.
- Metal shell provides EMI/RFI shielding. Plug shell indents provide grounding and additional mating retention.
- Grounding features include two-prong boardlock for exceptional retention to PC board.
- Mounting options for panel mount or connector mating include through-hole, threaded inserts and threaded standoffs.
- D-shaped connector mating outline provides polarization design based on requirements of MIL-C-24308, EIA RS-232 and RS-449.

SPECIFICATIONS

- Insulator Material: Thermoplastic polyester, UL 94V-0; chemical resistant; colour - black.
- Ferrite Specifications: Attenuation - 20dB MIN @ 30Mhz, 30dB MIN @ 50Mhz and 50db MIN @ 100Mhz.
- Contact Material: Plug contacts - brass; receptacle contacts - phosphor bronze.
- Contact Plating: Gold (see *Ordering Code*) over nickel for the mating area, tin/lead plating on contact tails.
- Shell Material: Nickel-plated steel (tin/lead optional)
- Current Rating: 5 amperes.
- Contact Resistance: 10 milliohms maximum.
- Dielectric Withstanding Voltage: 1000V AC rms at sea level.
- Insulation Resistance: 5000 megohms minimum.
- Operating Temperature: -55° to +105° C.
- Engagement and Separation Force: 1 to 10 oz. (0.28 to 2.78 N) per contact position.

SERIES

627Plug
628.....Receptacle

TOTAL CONTACTS

009, 015, 025, 037, 050

PLATING CODE

2Gold Flash (Class 3)
315µ" (0.38µm) (Class 2)
630µ" (0.76µm) (Class 1)

CONTACT CODE

20PC tail .125" (3.18mm)
21PC tail .165" (4.18mm)
22Solder cup termination
28Ferrite filter

EDAC INTERNAL USE

0Indicates generic internal use code

BODY STYLE

4Metal covered .276" (7.00mm) low profile
5Metal covered .472" (12.00mm) high profile
6Metal covered machined contacts low profile

MOUNTING OPTION

1125" (3.18mm) dia. through-hole
2#4-40 UNC threaded inserts
3#4-40 UNC threaded standoffs
6#4-40 UNC threaded insert with boardlocks
7#4-40 UNC threaded standoff with boardlocks
8#4-40 UNC threaded fixed standoffs

627/628 SERIES

LOW PROFILE

PLUG 627 SERIES

HIGH PROFILE

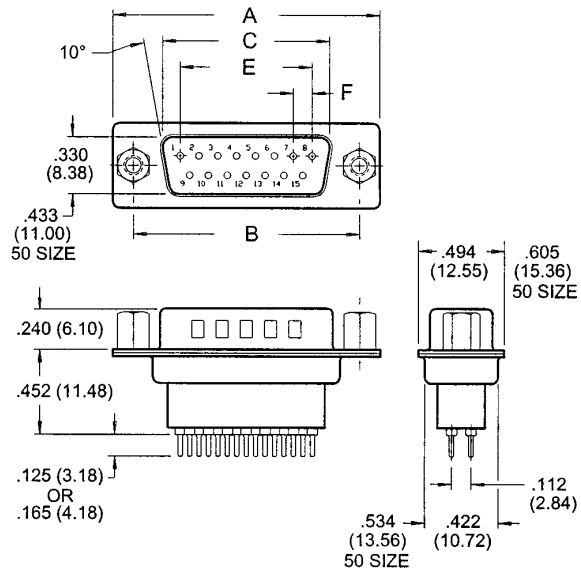
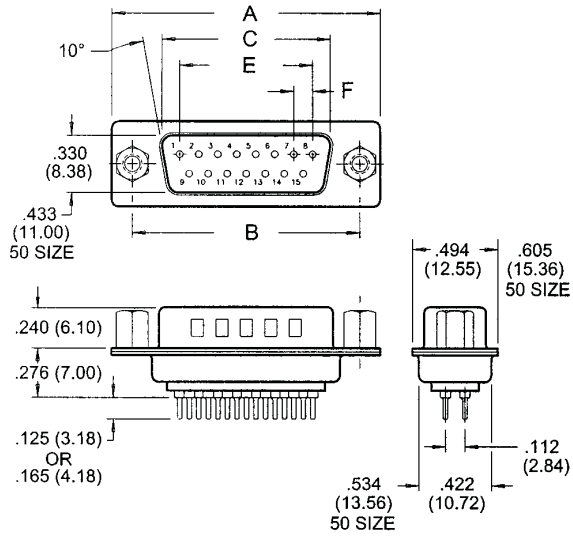

RECEPTACLE 628 SERIES

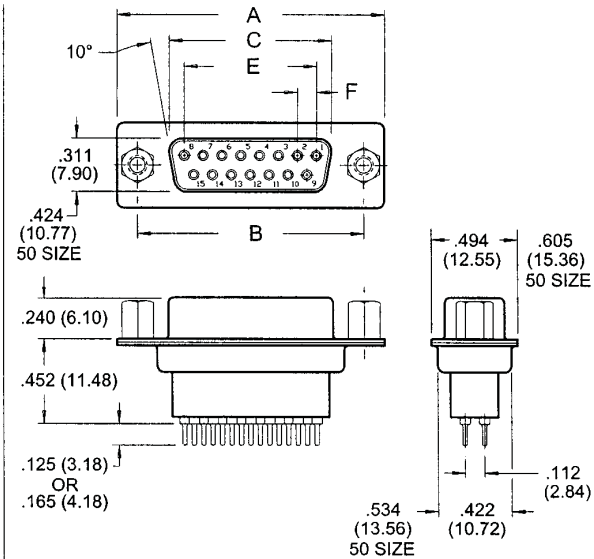
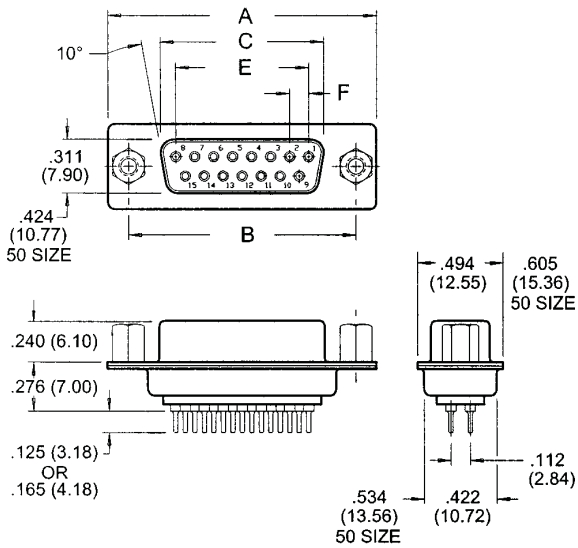

NUMBER OF CONTACTS	A		B		C PLUG		C RECEPTACLE		E		F	
	Inch	(mm)	Inch	(mm)	Inch	(mm)	Inch	(mm)	Inch	(mm)	Inch	(mm)
9	1.214	(30.84)	.984	(24.99)	.667	(16.92)	.640	(16.26)	.432	(10.97)	.108	(2.74)
15	1.545	(39.24)	1.312	(33.32)	.994	(25.25)	.967	(24.56)	.756	(19.20)	.108	(2.74)
25	2.088	(53.04)	1.852	(47.04)	1.534	(38.96)	1.508	(38.30)	1.304	(33.12)	.109	(2.76)
37	2.730	(69.34)	2.500	(63.50)	2.182	(53.08)	2.156	(54.76)	1.956	(49.68)	.109	(2.76)
50	2.640	(67.05)	2.406	(61.11)	2.080	(52.83)	2.054	(52.17)	1.740	(44.20)	.109	(2.76)

Plug and Receptacle, Vertical, PCB Mount, METAL Body Configurations